



Designation: C1279 – 23

Standard Test Method for Non-Destructive Photoelastic Measurement of Edge and Surface Stresses in Annealed, Heat-Strengthened, and Fully Tempered Flat Glass¹

This standard is issued under the fixed designation C1279; the number immediately following the designation indicates the year of original adoption or, in the case of revision, the year of last revision. A number in parentheses indicates the year of last reapproval. A superscript epsilon (ϵ) indicates an editorial change since the last revision or reapproval.

1. Scope

1.1 This test method covers the determination of edge stresses and surface stresses in annealed, heat-strengthened, and fully tempered flat glass products.

1.2 This test method is non-destructive.

1.3 This test method uses transmitted light and is, therefore, applicable to light-transmitting glasses.

1.4 The test method is not applicable to chemically-tempered glass.

1.5 Using the procedure described, surface stresses can be measured only on the “tin” side of float glass.

1.6 Surface-stress measuring instruments are designed for a specific range of surface index of refraction.

1.7 The values stated in SI units are to be regarded as standard. No other units of measurement are included in this standard.

1.8 *This standard does not purport to address all of the safety concerns, if any, associated with its use. It is the responsibility of the user of this standard to establish appropriate safety, health, and environmental practices and determine the applicability of regulatory limitations prior to use.*

1.9 *This international standard was developed in accordance with internationally recognized principles on standardization established in the Decision on Principles for the Development of International Standards, Guides and Recommendations issued by the World Trade Organization Technical Barriers to Trade (TBT) Committee.*

¹ This test method is under the jurisdiction of ASTM Committee C14 on Glass and Glass Products and is the direct responsibility of Subcommittee C14.08 on Flat Glass.

Current edition approved Nov. 1, 2023. Published December 2023. Originally approved in 1994. Last previous edition approved in 2019 as C1279 – 13 (2019). DOI: 10.1520/C1279-23.

2. Referenced Documents

2.1 ASTM Standards:²

C158 Test Methods for Strength of Glass by Flexure (Determination of Modulus of Rupture)

C162 Terminology of Glass and Glass Products

C770 Test Method for Measurement of Glass Stress—Optical Coefficient

C1048 Specification for Heat-Strengthened and Fully Tempered Flat Glass

E691 Practice for Conducting an Interlaboratory Study to Determine the Precision of a Test Method

2.2 Other Documents:

*Engineering Standards Manual*³

“Surface and Edge Stress in Tempered Glass”⁴

3. Terminology

3.1 Definitions:

3.1.1 *analyzer*—a polarizing element, typically positioned between the specimen being evaluated and the viewer.

3.1.2 *polarizer*—an optical assembly that transmits light vibrating in a single planar direction, typically positioned between a light source and the specimen being evaluated.

3.1.3 *retardation compensator*—an optical device, variants of which are used to quantify the optical retardation produced in transparent birefringent materials: typically positioned between the specimen being evaluated and the analyzer.

3.2 For definition of terms used in this test method, refer to Terminology C162.

² For referenced ASTM standards, visit the ASTM website, www.astm.org, or contact ASTM Customer Service at service@astm.org. For *Annual Book of ASTM Standards* volume information, refer to the standard’s Document Summary page on the ASTM website.

³ Available from Glass Association of North America (GANA), 800 SW Jackson Street, Ste 1500, Topeka, Kansas 66612–1200. <http://www.glasswebsite.com>.

⁴ Redner, A. S. and Voloshin, A. S., Proceedings of the Ninth International Conference on Experimental Mechanics, Denmark, 1990.

4. Summary of Test Methods

4.1 Two test methods are described in this standard:

4.1.1 Procedure A—describes a test method for measuring surface stress using light propagating nearly parallel to the surface.

4.1.2 Procedure B—describes a test method for measuring edge-stress using light propagating in the direction perpendicular to the surface.

4.2 In both methods, the fundamental photoelastic concept is used. As a result of stresses, the material becomes optically anisotropic or birefringent. When polarized light propagates through such anisotropic materials, the differences in the speed of light rays vibrating along the maximum and minimum principal stress introduce a relative retardation between these rays. This relative retardation is proportional to the measured stresses, and can be accurately determined using compensators. For additional background see “Surface and Edge Stress in Tempered Glass.”⁴

5. Significance and Use

5.1 The strength and performance of heat-strengthened and fully-tempered glass is greatly affected by the surface and edge stress induced during the heat-treating process.

5.2 The edge and surface stress levels are specified in Specification C1048, in the Engineering Standards Manual³ of GANA Tempering Division and in foreign specifications.

5.3 This test method offers a direct and convenient way to non-destructively determine the residual state of stress on the surface and at the edge of annealed and heat-treated glass.

6. Principles of Operation

6.1 Procedure A: Measuring Surface Stress:

6.1.1 Measurement of surface stresses requires an optical apparatus that permits the injection of polarized light rays propagating in a thin layer adjacent to the surface (see Note 1). A prism is usually used for this purpose. The rays emerge at critical angle i_c . The photoelastic retardation due to the surface stresses, (see Fig. 1), is measured using a wedge-compensator.

6.1.2 The incident light beam should be arriving at the critical angle i_c and polarized at 45° to the entrance of the prism edge. A quartz wedge-compensator, W_c , placed in the path of emerging light adds a retardation, R_c , to the retardation R_s induced by stresses in the surface of the specimen. The

analyzer, A , placed between the eyepiece, E , and the wedge-compensator, W_c , generates a visible set of fringes or lines of constant retardation R where

$$R = R_s + R_c \tag{1}$$

Since the specimen-induced retardation is proportional to the surface stress, S , and the path, t , we have:

$$R_s = C \cdot S \cdot t = C \cdot S \cdot ax \tag{2}$$

where:

- R = is the relative retardation,
- C = stress-optical constant (see Note 2),
- S = surface stress in the direction perpendicular to the path, t
- t = path of light traveling between the entrance and exit points 1, 2 (Fig. 1), and
- a = Geometrical factor, (depending upon the prism design) $a = t/x$. This constant is determined by the manufacturer.

6.1.3 The compensator adds its own retardation. It is linearly variable along its length y and is calculated as

$$R_c = b \cdot y \tag{3}$$

Where b is a constant, determined by the manufacturer of the compensator. The observer sees in the compensator plane a total retardation R .

$$R = R_s + R_c = a \cdot C \cdot S \cdot x + b \cdot y \tag{4}$$

6.1.4 The fringes (lines of $R = \text{Constant}$) are, therefore, tilted lines. (See Fig. 2). The angle θ is the tilt of these fringes relative to a plane containing the light path of Figs. 1 and 2. The measured stress is proportional to the tangent of the tilt angle θ , measured using a goniometer, and to an instrument calibration constant, K MPa, determined by the manufacturer.

$$\tan \theta = \frac{a \cdot C \cdot S}{b} \text{ and} \tag{5}$$

$$\text{Stress} = \frac{b}{Ca} \cdot \tan \theta = K \cdot \tan \theta$$

In the actual procedure (see 15.1 below) the operator measures the tilt angle θ of the observed set of fringes.

NOTE 1—The surface-stress measuring apparatus described in this section is manufactured by Strainoptics, Inc. in North Wales, Pennsylvania. The measured stress reported by the Strainoptics apparatus is in the direction perpendicular to apparatus’ long axis.

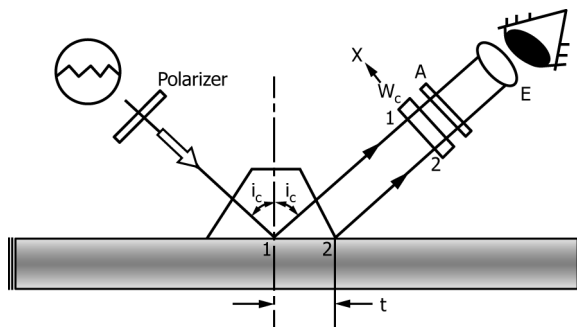

FIG. 1 Apparatus For Measuring Surface Stress

View of the Wedge, W_c

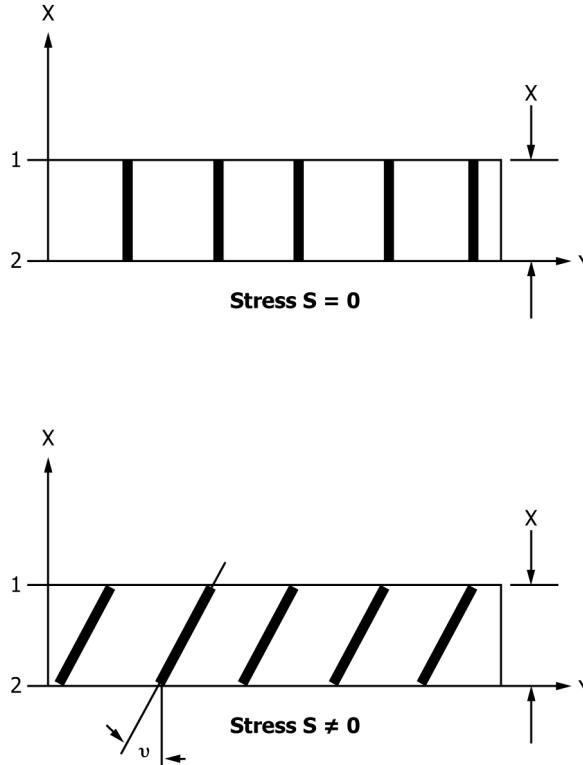

FIG. 1 Apparatus For Measuring Surface Stress (continued)

Rotate protractor to align crosshair parallel with observed fringes.

Read angle θ and use Equation 4 to convert angle θ to stress.

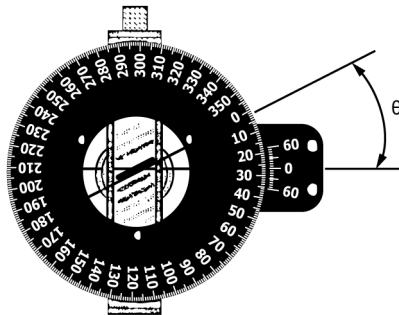

FIG. 2 Fringes Observed in the Plane of the Compensator

NOTE 2—The stress constant of float glass is typically 2.55 to 2.65 Brewsters. Calibration can be performed using one of the test methods described in Test Methods C770.

6.2 Procedure B: Measuring Edge Stress:

6.2.1 Measurement of edge stress is accomplished using a polarimeter equipped with a wedge-compensator, as shown schematically in Fig. 3.

6.2.2 The angle between the polarizer and the edge of the specimen must be 45° (see Fig. 3a), and the analyzer must be perpendicular to the polarizer. The overall magnification should be at least $20\times$ to permit clear visibility of the reticle, and of photoelastic fringes near the edge. The reticle placed adjacent to the specimen must have graduations of 0.1 mm (0.004 in.) or smaller. The resolution of the compensator should be at least 5 nm, and the compensator should be

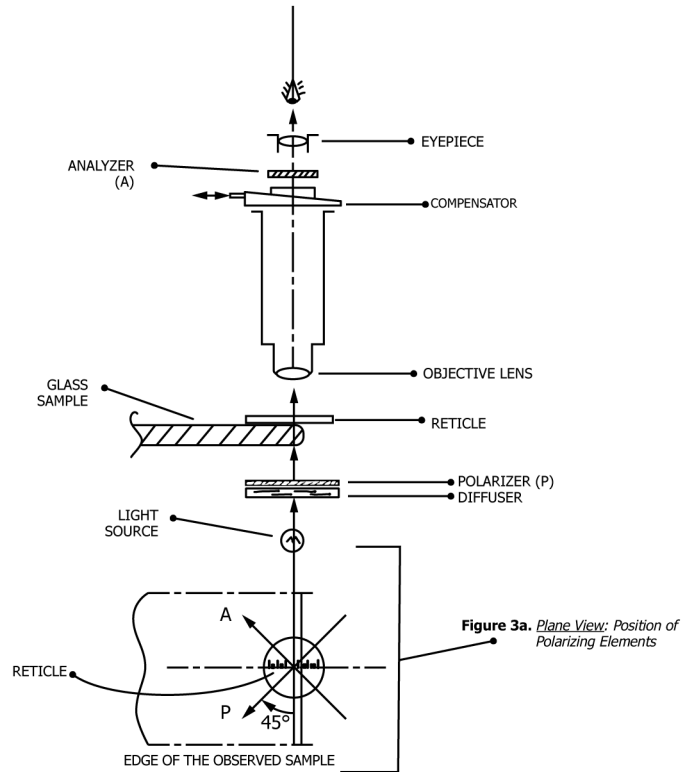

FIG. 3 Schematic of the Instrument for Measuring Edge Stress